

Ardea Coaching Wheel of Life

The Wheel of Life is a coaching tool that can help you look at different areas of your life and see where you are in balance and where you might be out of balance. It's an easy process. The instructions are below, and the worksheet is on the next page.

Step 1: Pick Your Life Areas

On the worksheet, you will find that the Wheel of Life is divided into eight "pie pieces." The first task is to label each section of the Wheel with a different area of your life. The categories I like to use are: Career, Money & Prosperity, Health, Friends & Family, Significant Relationship(s), Personal Growth, Fun & Recreation, and Service. Your categories may be different. A few more ideas: Spirituality, Physical Environment/Home, Communication, Time Management, Organization and Planning, Political Involvement. Whatever you pick as your eight areas, label them on the numbered lines next to each section of the Wheel. Also label the numbered lines underneath the Wheel with the same categories.

Step 2: Rate Your Satisfaction

The second step is to rate your current level of satisfaction with each area. The Wheel has several rings. The outer ring represents 100% satisfaction. The middle ring represents 50% satisfaction. Of course, the point in the center of the circle represents 0% satisfaction. Fill in each section of the Wheel to represent your feeling of satisfaction with that area of your life.

Step 3: Look at What You Might Change

Look at the Wheel. How round is it? The rounder the wheel, the more balanced your life. If this was a literal wheel on a car or bicycle, how smooth would the ride be? Pick one or two of the sections that you'd most like to see change in. On the three lines for that section (in the area below the Wheel), brainstorm a few things that you could do *today or tomorrow* to start changing this area of your life for the better.

Step 4: Make Change Happen

Do one or more of your brainstormed actions right away. Get into action. Do another action, however small, each day to move you in the right direction!

If you'd like ongoing support for creating a plan to smooth out your Wheel, consider hiring a coach. Interview at least three to find one who matches your needs and your style. Ask if they are certified through the International Coach Federation (ICF) or an ICF-accredited training program. Many coaches offer a free sample session to let you see them in action, risk free.

I offer a sample session, as well as referrals to other coaches trained by ICF-accredited programs. Feel free to contact me for ideas, resources, or referrals.



Michael J. Coffey
Certified
Professional
Coach

Envision, plan,
and live the life
of your dreams.

P.O. Box 23221
Seattle, WA 98102

(206) 52-COACH
(206) 522-6224

michaelc@ArdeaCoaching.com
<http://www.ArdeaCoaching.com>

Ardea Coaching Wheel of Life

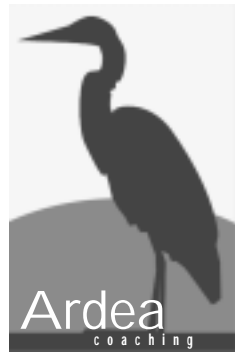

*Michael J. Coffey
Certified
Professional
Coach*

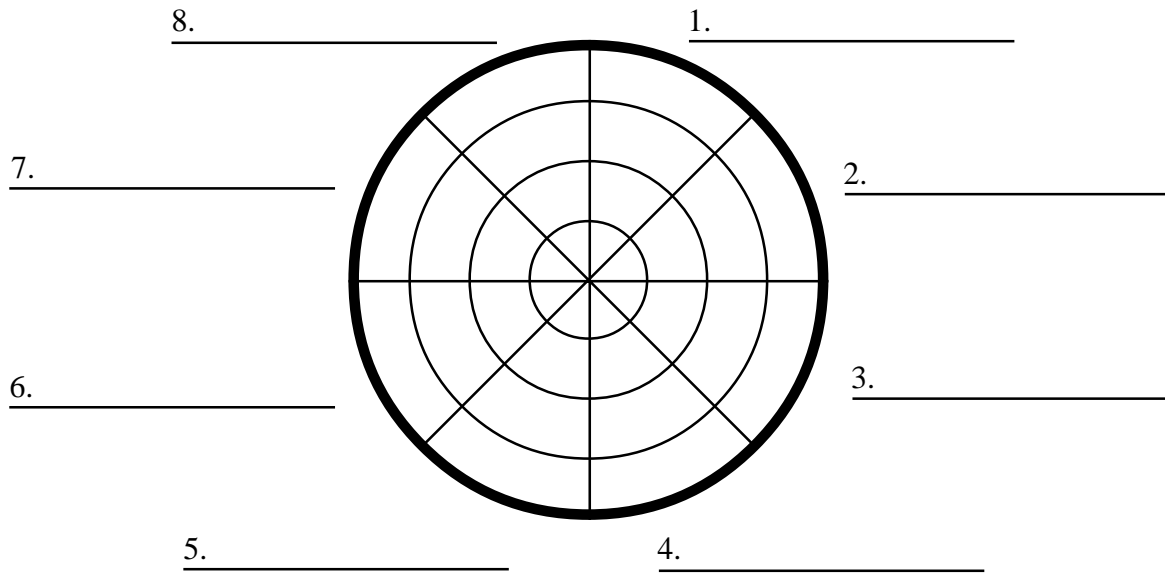

1. _____
 A. _____
 B. _____
 C. _____

2. _____
 A. _____
 B. _____
 C. _____

3. _____
 A. _____
 B. _____
 C. _____

4. _____
 A. _____
 B. _____
 C. _____

5. _____
 A. _____
 B. _____
 C. _____

6. _____
 A. _____
 B. _____
 C. _____

7. _____
 A. _____
 B. _____
 C. _____

8. _____
 A. _____
 B. _____
 C. _____

P.O. Box 23221
Seattle, WA 98102

(206) 52-COACH
(206) 522-6224

michaelc@ArdeaCoaching.com
http://www.ArdeaCoaching.com